

Assemble circuits of voltage stabilizer and UPS

Objectives: At the end of this exercise you shall be able to

- construct voltage stabilizer circuit on PCB
- test the stabilizer for its low and high cut-off ranges
- assemble 'ON' line UPS with assembled PCB modules/circuit boards
- test the 'ON' line UPS for its function.

Requirement

Tools/Instruments

- Trainees tool kit - 1 No.
- Multimeter - 1 No.
- AC Voltmeter 0-300 V - 1 No.
- Variac 0-300V/1A - 1 No.

- Resistors carbon film 1/2 W
1K5, 3K3, 1K - 2 Nos. each
- 560Ω, 100Ω - 2 Nos. each
- 4K7, 47K - 3 Nos. each
- 1K Pot - 1 No.
- Electronic relay - 170V - 270 V/6V moulded type : 3 pin - 2 Nos. each

Materials

- General purpose PCB - 1 No
- Transistors - BC 147/157 - 2 Nos.
- CL 100 - 2 Nos.
- Diode IN 4007 - 2 Nos.
- Zener diode 6V/0.5A - 1 No.
- LED, red & green - 1 No. each
- Inductor - 21 SWG Ferrite core 100 turns - 2 Nos.
- Capacitor - 330 μF/12V - 3 Nos.
- 100 μF/12V - 4 Nos

- Buck - boost mains transformer 170V - 270V - 1 KVA 0-6 A, 0-6 V AC - 1 No.
- Assembled modules or PCBs of a ON line UPS - 1 Set
- Incandescent lamps fitted in pendent holders - 1 No.
- Connecting wires/cables - as reqd.
- Solder, flux etc. - as reqd.

PROCEDURE

TASK 1: Construct voltage stabilizer circuit on PCB

- 1 Solder the components on general purpose PCB as per the circuit (Fig 1). Do not fix the transformer on PCB.
- 2 Connect the wires or cables from the PCB to connect with transformer winding terminals.

Fig 1

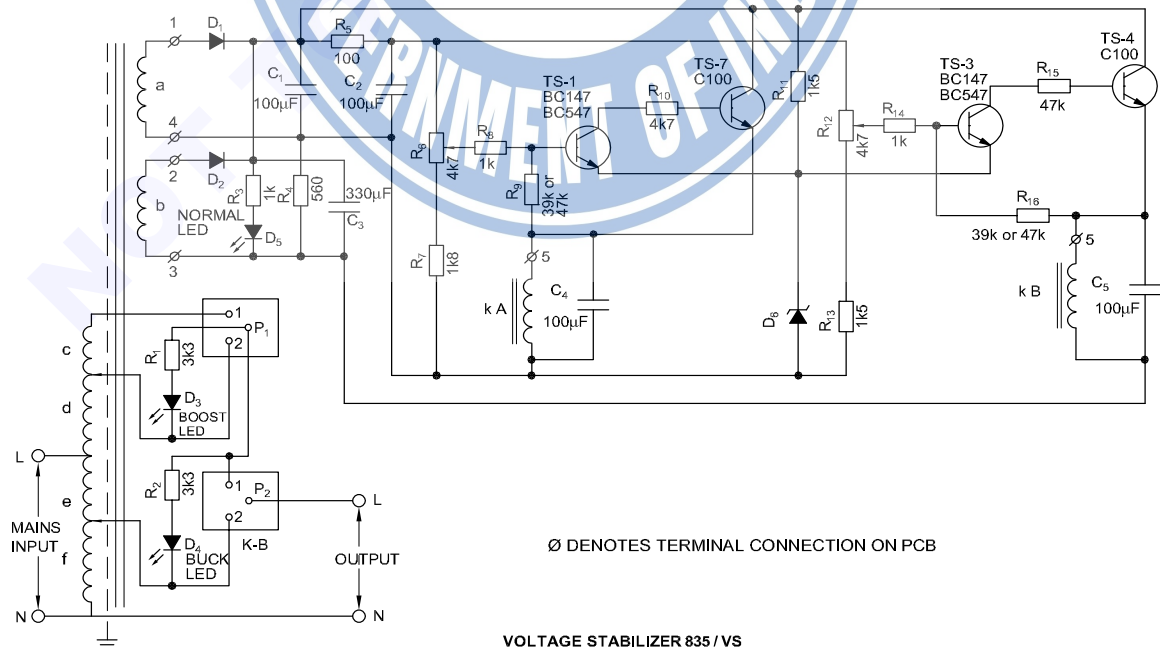

EL20N210175H1

- Finish the wiring and clean the PCB; check the wiring for its correctness.
- Connect the transformer input wires to the Variac for testing the circuit. Connect the incandescent lamp in the output of stabilizer. (Fig 2)

- Switch 'ON' the supply to Variac and slowly increase the voltage till normal LED glow and output lamp glow.
- Switch 'OFF', remove the lamp and connect the voltmeters. Do not change the variac position.

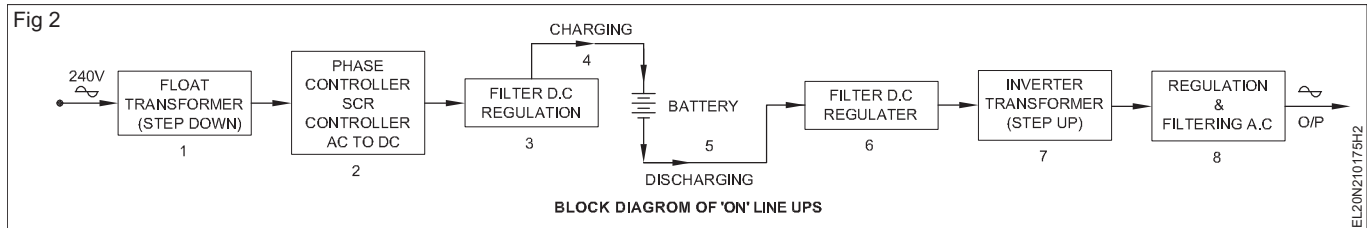

- Switch 'ON' the supply and note down the voltage in Table 1.
- Test the bulk-boost action by increasing and decreasing of Variac voltage increase the variac voltage.
- Check the voltmeter, starts to show increase in voltage initially; but drops to normal voltage. Note down both the voltage; Voltage in output and Voltage at Variac terminals. Record in the Table 1.

- Reduce the voltage of Variac and note the voltmeter reading. The voltmeter voltage will decrease but regains its normal position.
- Note this time voltage : Voltage at output and variac terminal voltage in the Table 1.

If the voltage is not changing when changing variac volt ; consult your instructor.

- Remove all connections and get your voltage readings approved by your instructor.

Table 1

SI. No.	Variac voltage position	Variac terminal voltage (Volt)	Output voltage (Volt)
1	Variac knob in Middle Position		
2	Increase from Middle Position		
3	Decrease from Middle Position		

TASK 2: Assemble of 'ON' line UPS using wired PCB modules

- Refer the block diagram in Task 1 and arrange the PCB wired modules.

- Wire the PCB modules as per the block diagram in Fig 2 in Task 1 and check the sequence as per the Fig 1.

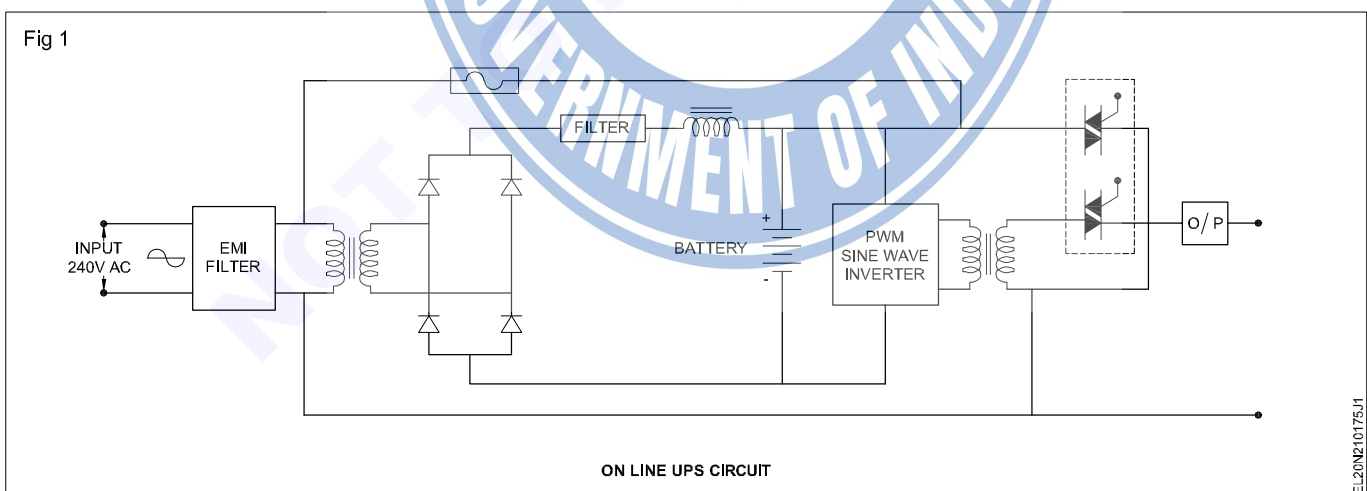

- Connect the charged battery without shorting the battery terminals. Connect one single pole switches initially with battery circuit.

- Connect the input to EMI filter. Check for any circuit problems. Switch 'ON' the circuit 240V AC. Check the output with Voltmeters. Record the meter reading in Table 1.

If it is not indicating any voltage and consult with your Instructor.

- 5 Switch 'ON' the battery. Check the voltage in the output and record the reading in Table 1.
- 6 Switch 'OFF' the Mains 240V and check the voltage in output, record the voltage in Table 1.

If no voltage consult with your instructor.

- 7 Connect the incandescent lamp in the output. Repeat steps 4 to 6.

- 8 Note the lamp brighten while input supply 220V. Switched 'ON' & 'OFF'.

If lamp is not glowing or dim consult with your Instructor.

- 9 Get your readings approved by your instructor.

Table 1

SI. No.	Input supply voltage	Output voltage (Volt)
1	'ON'	
2	'OFF'	



Prepare an emergency light

Objectives: At the end of this exercise you shall be able to

- assemble the components on the PCB and construct charging circuit for emergency light
- assemble inverter circuit for emergency light
- assemble charging circuit and inverter circuit for emergency light.

Requirements

Tools/Instruments

- | | | | |
|------------------------------------|---------|-------------------------------|----------|
| • Soldering iron 10W, 240V | - 1 No. | • Resistance 1K, 1/4W - 1 No. | |
| • Wire stripper 150mm | - 1 No. | • Resistance 2.2K, 5 W | - 2 Nos. |
| • Tweezer 150mm | - 1 No. | • Resistance 2.2 Ω 1/4 W | - 1 No. |
| • Insulated round nose plier 150mm | - 1 No. | • Capacitor 10 μF, 25V | - 1 No. |
| • Insulated wire cutter 150mm | - 1 No. | • Capacitor 1000 μF, 25V | - 1 No. |
| • Multimeter | - 1 No. | • Soldering flux | - 10 gms |

Materials

- | | | | |
|--|----------|---|------------|
| • Step down transformer centre tapped 240/7.5-0-7.5V, 2A | - 1 No. | • General purpose PCB 150mm x 100mm | - 1 No. |
| • Rectifier diode in 5402 | - 3 Nos. | • PVC insulated tinned copper cable 14/0.38 mm | - as reqd. |
| • Lead acid battery 6V, 10Ah, maintenance free type | - 1 No. | • P.V.C. Insulation tape 20mm, 10m | - 1 roll |
| • Toggle switch 2A, 240V SPST | - 1 No. | • Screw type incandescent lamp 6V 15W | - 1 No. |
| • Toggle switch 2A, 240 DPST | - 1 No. | • Transistor 2N 3055 with the heat sink | - 1 No. |
| • Relay 6V DC, 5A with one 'NO' and one 'NC' | - 1 No. | • Resistance 50Ω, 5W | - 1 No. |
| • Fuse unit with fuse 0.5A (glass type) | - 1 No. | • Capacitor 2.2 μF, 250V | - 1 No. |
| • Fuse unit with fuse 2.5A (glass type) | - 1 No. | • Inverter transformer 6V, 20W | - 1 No. |
| • LED holder 5mm | - 2 Nos. | • Complete fluorescent tube light fitting with 20W tube in suitable sheet metal box | - 1 Set |
| • LED 5mm red | - 1 No. | • Silicon grease | - 5 gms |
| • LED 5mm green | - 1 No. | | |

PROCEDURE

TASK 1 : Construct charging circuit for emergency light

- | | |
|---|--|
| 1 Draw the circuit diagram (Fig 1) of a simple emergency light circuit. | 8 Check the connection as per circuit diagram. |
| 2 Identify each component in the circuit. | 9 Switch 'ON' the AC supply for charging the battery. |
| 3 Test the collected components for their condition. | 10 Check the glow of red LED which is an indication for the presence of AC supply. |
| 4 Arrange the components except the battery on the PCB to meet the technical requirement and aesthetic sense. | 11 After charging the battery switch 'OFF' the AC supply, put 'ON' the lamp and observe the functioning of the emergency light and also check the indicator green LED is 'ON'. |
| 5 Draw the layout of the components of the PCB. | |
| 6 Mount the components on the PCB in the respective places. | |
| 7 Solder the components as per Fig 1. | |

Do not allow the emergency light battery to discharge fully.

While soldering the components ascertain correct polarity.

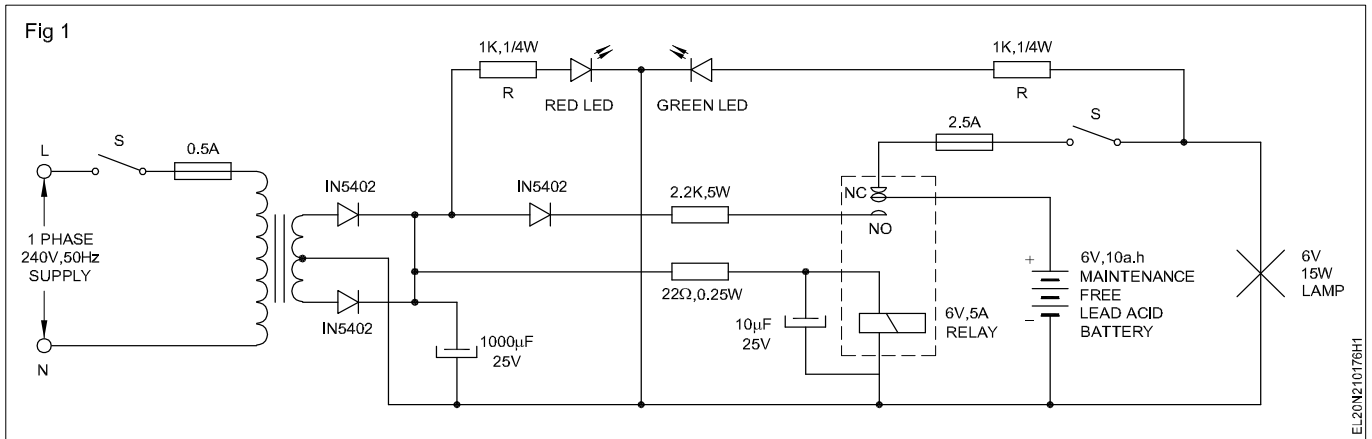

TASK 2 : Construct inverter circuit for emergency light

- Trace the circuit diagram of an emergency tube light circuit as per diagram. (Fig 1)
- Identify the each component of the circuit.
- Solder the components on PCB for making inverter circuit. (Fig 1)
- Mark the inverter circuit board with charging circuit.
- Test the emergency light after connecting fluorescent tube light.
- Fix permanently the charging unit, inverter and fluorescent tube suitably in a box/case.
- Check the indicating LED Red and Green functioning correctly.
- Get the work checked and approved by instructor.

Inverter circuit preferably to be assemble in a separate small PCB

- Mark the inverter circuit board with charging circuit.

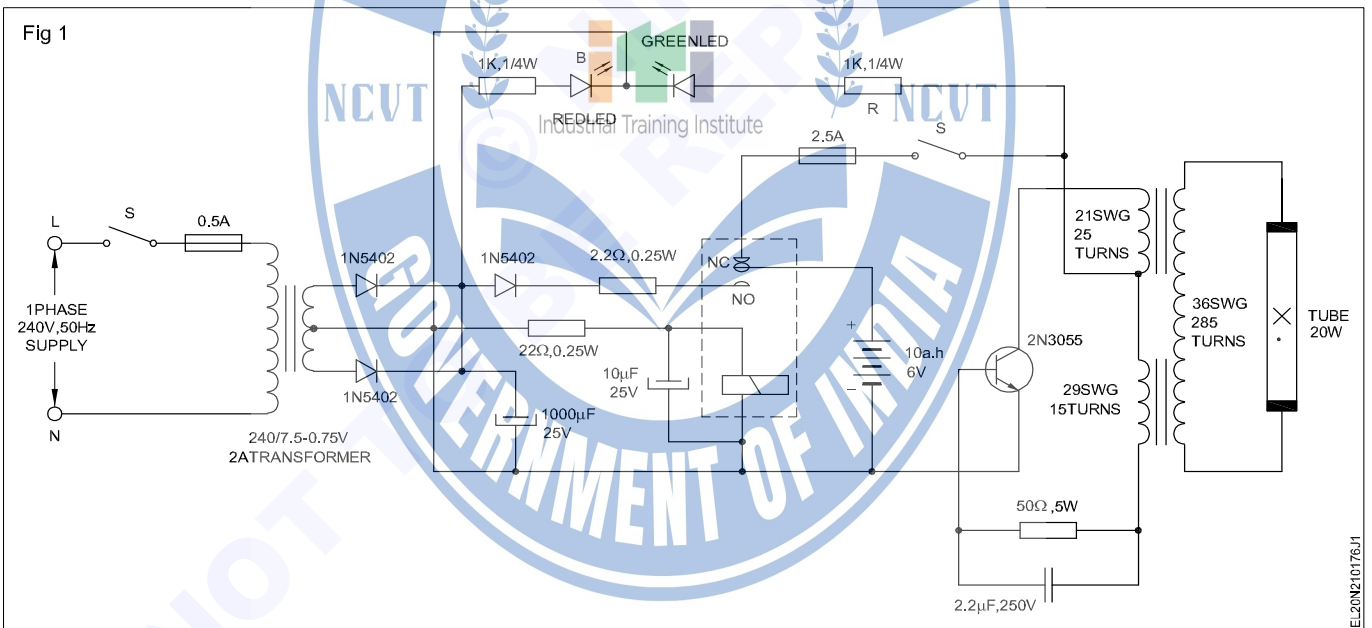

Assemble circuits of battery charger and inverter

Objectives: At the end of this exercise you shall be able to

- assemble the battery charging circuit wired on PCB and test it
- construct and test inverter.

Requirements			
Tools/Instruments			
• Trainees tool kit	- 1 Set	• Diodes for bridge 1N112	- 4 Nos.
• soldering iron 35W/250V	- 1 No.	• Capacitors-250µf/12V	- 1.No.
• De soldering gun 65W/250V	- 1 No.	• Resistors,10Ω, 1W	- 1 No.
• Star screw driver set (set of 6 Nos)	- 1 Set	• Pot 1.5Ω/10W	- 1 No.
• Ammeter 0-10 A M.C	- 1 No.	• Low voltage lamp 6.3V	- 1 No.
• Voltmeter 0-50V M.C	- 1 No.	• Fuse 250 mA	- 3 Nos.
• Digital multimeter (3 1/2 digits)	- 1 No.	• Neon lamp	- 1 No.
Equipments/Machinery			
• Auto transformer 0-270 V-5A	- 1 No.	• Buzzer 250V	- 1 No.
• Step down transformer 240/40V, 300VA	- 1 No.	• Soldering flux and 60/40 solder	- as reqd.
• Charger transformer with centre tapping 6V-0-6V,500mA	- 1 No.	• Diode IN5402	- 3 Nos.
• Sealed maintenance Free battery 6V/120AH	- 1 No.	• LED : Red and Green	- 1 No.
• Relays double pole	- 3 Nos.	• Transistor -2N 3055	- 1 No.
Materials/Components			
• PCB-115-General purpose	- 2 Nos.	• Resistor : 2.2Ω, 22Ω, 50Ω, 1K (1 Watt)	- 1 No. each
• Push button switches	- 2 Nos.	• Electrolytic capacitors 1000 µfd/25V, 10 µfd, 25V	- 2Nos. each
• Toggle switches 250V/6A	- 2 Nos.	• 2.2 µfd/250V	- 1 No.
• Diodes 1N4002	- 4 Nos.	• Relay NC/No 6V	- 1 No.
		• Transformer 240V/7.5 - 0 - 75V, 2A	- 1 No.
		• Inverter transformer-iron core laminated 21 SWG - 25 turns, 29 SWG - 15 turns - Primary	
		36 SWG - 285 turns - Secondary	- 1 No.
		• Fuse 2.5A, 0.5A	- 1 No. each
		• SP Switches (Toggle - 6V)	- 2 Nos.

PROCEDURE

TASK1 : Assemble the battery charging circuit

- 1 Select suitable PCB (wired PCB) and other components
- 2 Check all components ie. transformer, relays, battery for their good condition
- 3 Construct the transformers relays, and other components on PCB. (Fig 1)
- 4 Connect the charger Transformer (X1) to the auto transformer (X2).
- 5 Connect the secondary of charger transformer (X1) to the full wave bridge rectifier which supplies rectified voltage to the battery under charge through ammeter, voltmeter and potentiometer.
- 6 Connect the pole (P1) of relay (RL1) to A.C main supply and connect pole (P2) is cut off circuit.
- 7 Connect the poles (P1 & P2) to normally open (N/O) pin, which will switch 'OFF' AC Main supply to the circuit.
- 8 Connect the test switch (S3) to check battery polarity.
- 9 Connect the ON/OFF switch (S1) to the input of AC main supply.

Reset switch (S4) is used to reset the charger, when any fault occurs and the charger is cut off. The switch (S1) for ON/OFF.

Step down transformer (X3) keeps the cut off relay in energised condition when the main AC supply is cut off to the charger circuit. Relay (RL1) is used to cut off the AC main supply to the charger circuit.

Normally a fully charged lead acid battery voltage 2.1 V/cell, During on charge, and can be increased up to 2.7 V/cell. The voltage of a battery is multiple of the number of cells in that battery. The voltage on Fully discharged condition is 1.8 V.

Test analyse, defects and repair voltage stabilizer, emergency light and UPS

Objectives: At the end of this exercise you shall be able to

- analyse the defect and repair voltage stabilizer
- repair and maintenance of emergency light
- analyse the fault and repair the defects in UPS.

Requirements	
Tools/Instruments	
<ul style="list-style-type: none"> • Trainees Tool kit - 1 Set • Connector screw driver set - 1 Set • Line /Neon tester 500 V - 1 No. • Soldering iron 35 W/250V - 1 No. • Desoldering gun - 1 No. • Multimeter (analog (or) digital) - 1 No. • Clamp on meter - 1 No. 	<ul style="list-style-type: none"> • CRO 20 MHz/dual trace - 1 No. • Assembled circuit of voltage stabilizer in Ex. No. 4.4.183 • Assembled circuit of emergency light in Ex. No. 4.4.184 • Assembled circuit of 'ON Line' UPS in Ex. No. 4.4.183
Equipments	
<ul style="list-style-type: none"> • Common UPS 625 VA/12 V - 1 No. • Sealed lead acid battery with operation manual (maintenance free battery) 12V/120AH - 1 No. 	Materials/Components <ul style="list-style-type: none"> • Spare components - as reqd. • Solder 60/40 - as reqd. • Soldering flux - as reqd. • Connecting wires - as reqd.

PROCEDURE

TASK 1: Analyse the fault and repair of voltage stabilizer with the help of a Service Flow Sequence (SFS)

- 1 Check the circuit carefully before connecting the supply for any short circuit in the components/parts in the stabilizer.
- 2 Connect the main supply cable into ohm meter and check the resistance by switch 'ON' the circuit (note to be connect with AC mains)

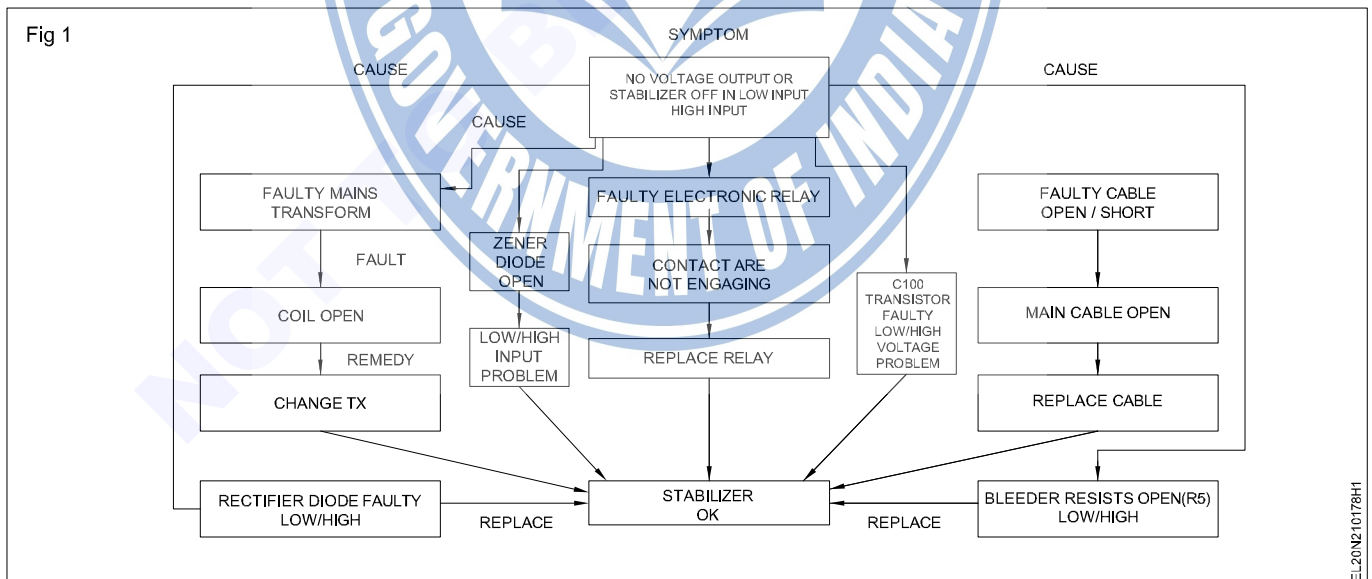

If it shows '0' resistance, it indicates a dead short. Consult your instructor.

If the meter shows infinity i.e. open circuit. Otherwise, if it is a healthy circuit it will show some resistance reading.

- 3 Check for any open circuit visually or by ohm meter after testing for short circuit.

- 4 Analyze the status of the circuit by the meters reading.

5 If the stabilizer is without short circuit fault, connect it to the supply mains and switch 'ON'. Check the

symptoms of the unit, and record the symptoms. Analyze the fault with the help of service flow sequence.

TASK 2: Repair and maintenance of emergency light with the help of trouble shooting sequence block

1 Steps 1 to 5 on as same as follow in Task 1 . Refer the service flow sequence diagram and solve it. (Fig 1)

There may be single fault or multi fault involving more components. A visual check will help in to find burning of components, dry soldering, loose connection, etc. A careful visual check is very much essential.

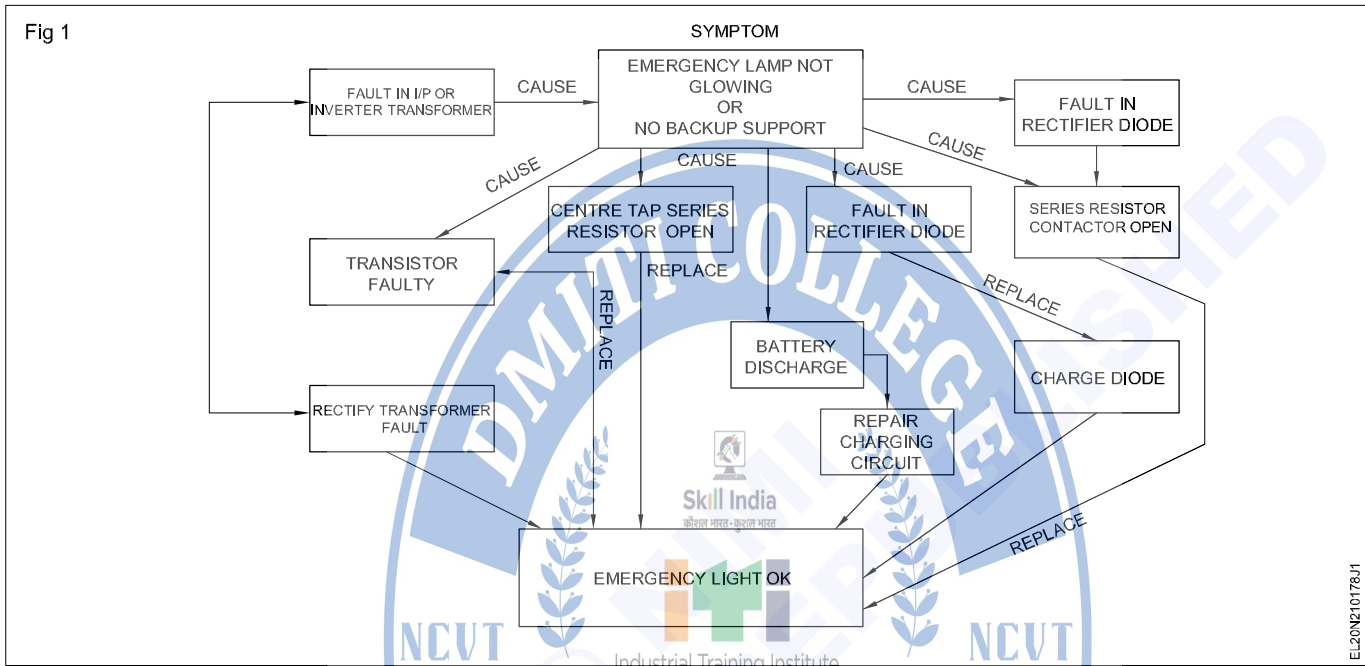

TASK 3 : Test UPS and identify the faults and rectify

- 1 Read and interpret the name plate details of the given UPS
Type of UPS.....ON line/OFF line
Model
Power ratingVA
Change over timem sec
Battery rating
Back up timeHours

- 4 Identify the problem by self testing UPS., and rectify this fault by referring the trouble shoot sequence block diagram (Fig 1)
- 5 To switch 'OFF' the UPS press and hold the ON/OFF/ test/ silence button for more than 3 seconds until the "Line normal" or "backup" LED 'OFF'.
- 6 Check the condition of switch, (or) back up LED (yellow LED) (or) press the switch for more than 3 seconds and rectify the problem, if the UPS not switched 'OFF'.

- 2 Switch 'ON' the UPS, with UPS. 'Plugged in'
- 3 Press and hold the ON/OFF /test /silence button for more than one second until "Line normal 'LED green lights up. (i.e U.P.S .'ON' and ready for use)

To de-energise the UPS properly in emergency, the right way is to switch 'OFF' the output switch to 'OFF' position and disconnect the power cord from the main supply.

If green LED does not light up, the possible causes may be (i) button not pressed (or) pressed to short (ii) voltage of battery less than 10V (iii) PCB - failure and (iv) load may be less than 20 W at battery mode.

- 7 Press the ON/OFF/test/silence switch, more than 3 seconds, to switch 'OFF' the UPS and battery.
- 8 Check the back up (LED yellow).

If the yellow LED (back up) lights 'OFF', the UPS and battery is on 'OFF' position. If the back LED is not 'OFF', it indicates UPS always at battery mode. The causes for this fault may in power cord, fuse or up normal voltage.

- 9 Check the condition of power cord, A.C fuse, abnormal voltage and PCB.
- 10 Rectify problem by referring the trouble shooting sequence block diagram (Fig 1)
- 11 Press the ON/OFF/TEST silence button less than one second, when A.C mains supply is available observe the operation UPS

If the UPS operates on load on battery mode, then battery LED lights up, it indicates UPS is in 'ON' line operation.

If the UPS does not operate on load on battery mode and immediately returns to 'ON' line operation and lights up the RED-LED, it indicates that the back up time is too short the battery is to be replaced (or) to be recharged.

- 12 Recharge the battery immediately for atleast four hours.
- 13 Check and test UPS with recharged battery and rectify the fault by referring Fig 1, Trouble shooting sequence block diagram.

If the "replace battery" (red LED) is still on, replace the battery.

- 14 Press the ON/OFF/test/silence button for less than 1 sec in 'Backup' mode, observe the audible alarm, It should be 'silence'.

If does not function under 'Low battery (or) over load conditions.

- 15 Check the beeping alarm, when pressing the silence button to stop the operation of UPS.

If it is stopped in back up mode it indicates UPS is in normal. But, If the beep sound alarms continuing, It indicates that UPS is over loaded.

- 16 Press the button (ON/OFF) during alarms to stop the beeping when yellow LED (backup) lights up.
- 17 Check for the maximum connected load to UPS and rectify this fault by disconnect the excess until the beep alarm is not available.

Fig 1

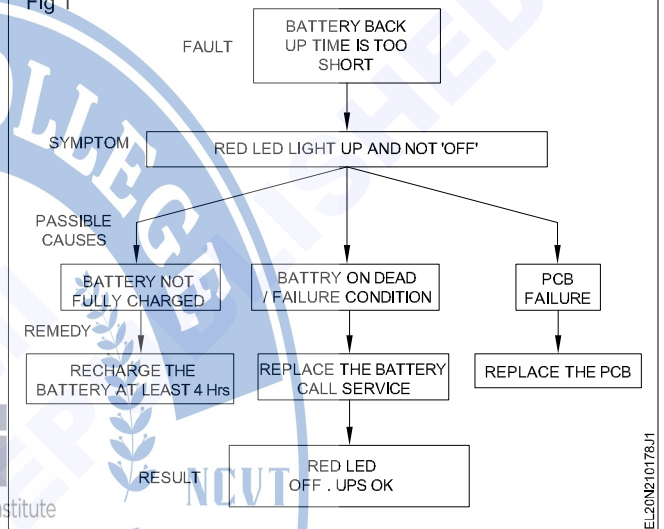

Maintain service and troubleshoot battery charger and inverter

Objectives: At the end of this exercise you shall be able to

- carryout service and troubleshoot a battery charger
- troubleshoot and repair a inverter.

Requirements		
Tools/Equipments		Material
<ul style="list-style-type: none"> • Trainees kit • Multimeter 	<ul style="list-style-type: none"> - 1 No. - 1 No. 	<ul style="list-style-type: none"> • Collect the circuits already constructed in Ex.No. 2.10.177

PROCEDURE

TASK 1: Service and troubleshoot of battery charger

- 1 Trace the battery charger circuit made in Ex.2.10.177 as in Fig 1.
- 2 Check the circuit for an availability of charging volt at battery connecting terminals.

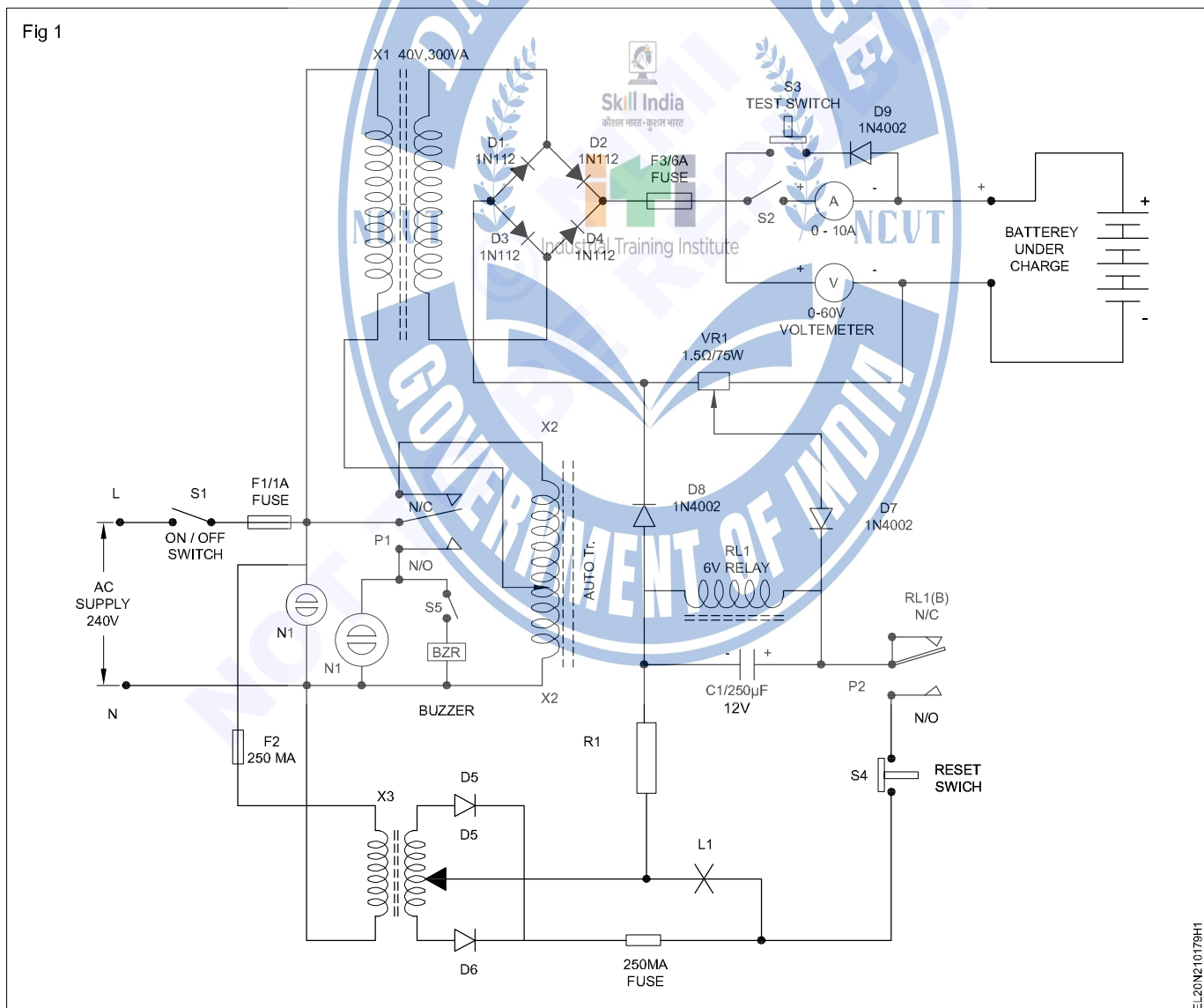

- 3 Check the fuse provided in the fuse carrier. If the voltage is not available.
- 4 Test the voltage output at the bridge rectifier output with multimeter.
- 5 Check the conditions of bridge rectifies diodes if found defective replace. If no voltage available.
- 6 Check the AC input to Bridge network. If the diodes are OK.
- 7 Check the relay contacts and; ensure supply is available at primary of the auto transformer. If the AC is not available
- 8 Check the charging control circuit for normal working after the charging circuit is repaired.
- 9 Check that auto cut-off of AC Mains is 'OFF' the battery is fully charged.

- 10 Check the diode connected to potentiometer and voltage at relay terminals, If auto cut-off is not working or functioning, and if the voltage is present at relay terminal (pole) Auto cut-off is OK.
- 11 Check the conditions of the battery, fully charged battery will show DC Voltage in no load about 20% more than the rated voltage.

Do not allow the battery Voltage (no-load) drop below 70% of the rated voltage. If it is so revival of the battery is difficult.

- 12 Check while charging battery; ensure that it is topped-up with distilled water and caps are removed for easy gaseous out from the cells.
- 13 Complete the work and show to your instructor for approval.

TASK 2: Service and troubleshoot of inverter circuit

- 1 Trace the circuit made in Ex. No.2.10.177 (Inverter circuit) and locate the Active Components. (Fig 1)
- 2 Carry out short circuit and open circuit test.

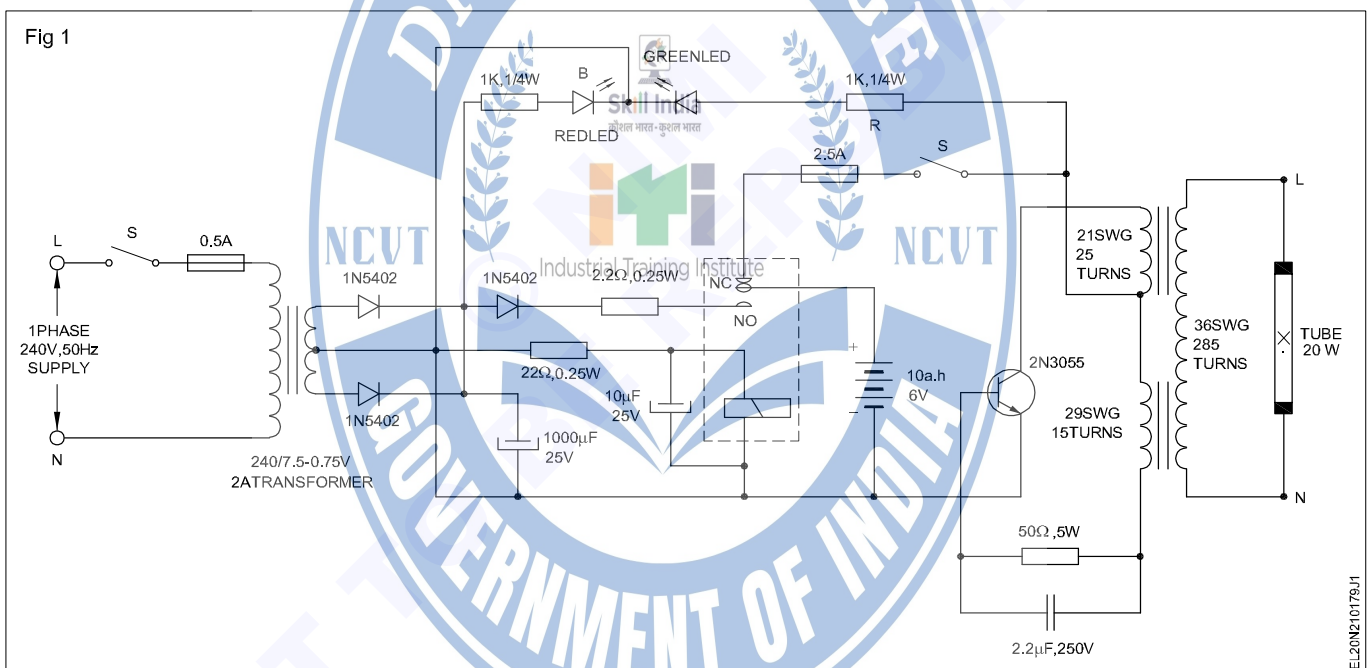

- 3 Remove the battery connect to AC Voltage check the inverter output with mains 'ON'.
- 4 Check the continuity of inverter transformer primary and secondary windings. If then is no output.
- 5 Check the transistor 2N3055 and the base supply. If the transformer is OK,
- 6 Check the fuse provided with NC of relay and check the conditions of relay contacts.
- 7 Check the rectifier diodes and bleeder resistor connections secondary to the Mains transformer.
- 8 Check the mains transformer primary and secondary windings. Check the main fuse.
- 9 Once the repair is completed check the output voltage without battery connections.
- 10 Connect the charged battery if output is available and operate it and ensure its working. Maintenance of battery is explained in the Task 1 and follow the same.
- 11 Complete the work and show to your instructor for approval.

Install an inverter with battery and connect it in domestic wiring for operation

Objectives: At the end of this exercise you shall be able to

- select the proper rating of inverter to install
- select suitable place for the inverter in the house
- select a correct rating of battery and the place to keep with inverter
- install the inverter and make connection to the load
- test the inverter for its good performance in 'OFF' and 'ON' supply mains.

Requirements	
<p>Tools/Instruments</p> <ul style="list-style-type: none"> • Trainees kit - 1 Set • Portable electric drilling machine 6mm - 1 No • Star head screw driver set (set of 6mm) - 1 No. • Rawl jumper No.8 - 1 No. • Cutting plier 150mm - 1 No. • D.E spanner set 6mm-25mm - 1 Set • Ballpein hammer 0.75 kg - 1 No • Single phase energy meter 250V/15A - 1 No • Multi pin socket 3/5 pin 250V/6A - 1 No. <p>Equipments/Machinery</p> <ul style="list-style-type: none"> • 200W/250V/6A-inverter - 1 No. • Battery 12V/120AH - 1 No. 	<p>Materials/Components</p> <ul style="list-style-type: none"> • 4 way MCB -20A - 1 No. • 1.5mm² P.V.C. copper (1/18)wires - as reqd. • Auto wires (stranded) - as reqd. • I.C.D.P switch 16A/250V - 1 No. • 4 way MCB/ICDP20 A switch - 1 No • Power socket 250 V/16A - 1 No • Multi pin wall socket 250V/6A (2 in one)with switch - 1 No • Grease/Vaseline - as reqd.

PROCEDURE

TASK 1: Select, install inverter with battery to connect in domestic wiring

- 1 Select the suitable rating of the Inverter considering the total connected load in that house, like fan, lamp etc.

The rating of the inverter should not exceed 60% capacity of the inverter key. (for a 100w inverter, total load should not be more than 60W).

- 2 Select the right place to install the inverter, where good ventilation is available.

The place for installation for inverter should be nearer to the D.P switch and the energy meter position.

- 3 Select the correct place to install battery, which is nearer to the inverter and to the ventilation.
- 4 Install the inverter and battery close to each other.

Do not provide the battery away from inverter. If should be closed to the inverter because it helps in reducing the current loss due to resistance of wire.

- 5 Make wiring connection to the inverter with 1.5 mm² wire.
- 6 Connect the three pin output socket from the mains supply (Fig 1)
- 7 Connect the positive terminal of the battery (i.e red wire) to the place provided for the positive terminal on the Inverter.
- 8 Connect the negative terminal of the battery (i.e black wire) to the place provided for the negative terminal of the inverter.

When connecting battery terminals to the inverter use special auto wires, do not use common 3/20 (or)7/20 wires and ensure that the battery is fully charged.

- 9 Put grease (or) vaseline on the battery terminals for reducing the terminal corrosion.
- 10 Complete the connection Take the output from the inverter output socket and use it to power the load.

To connect the inverter output to the load use only 1/18 wire, and do not use 3/20 or 7/20 wires.

Fig 1

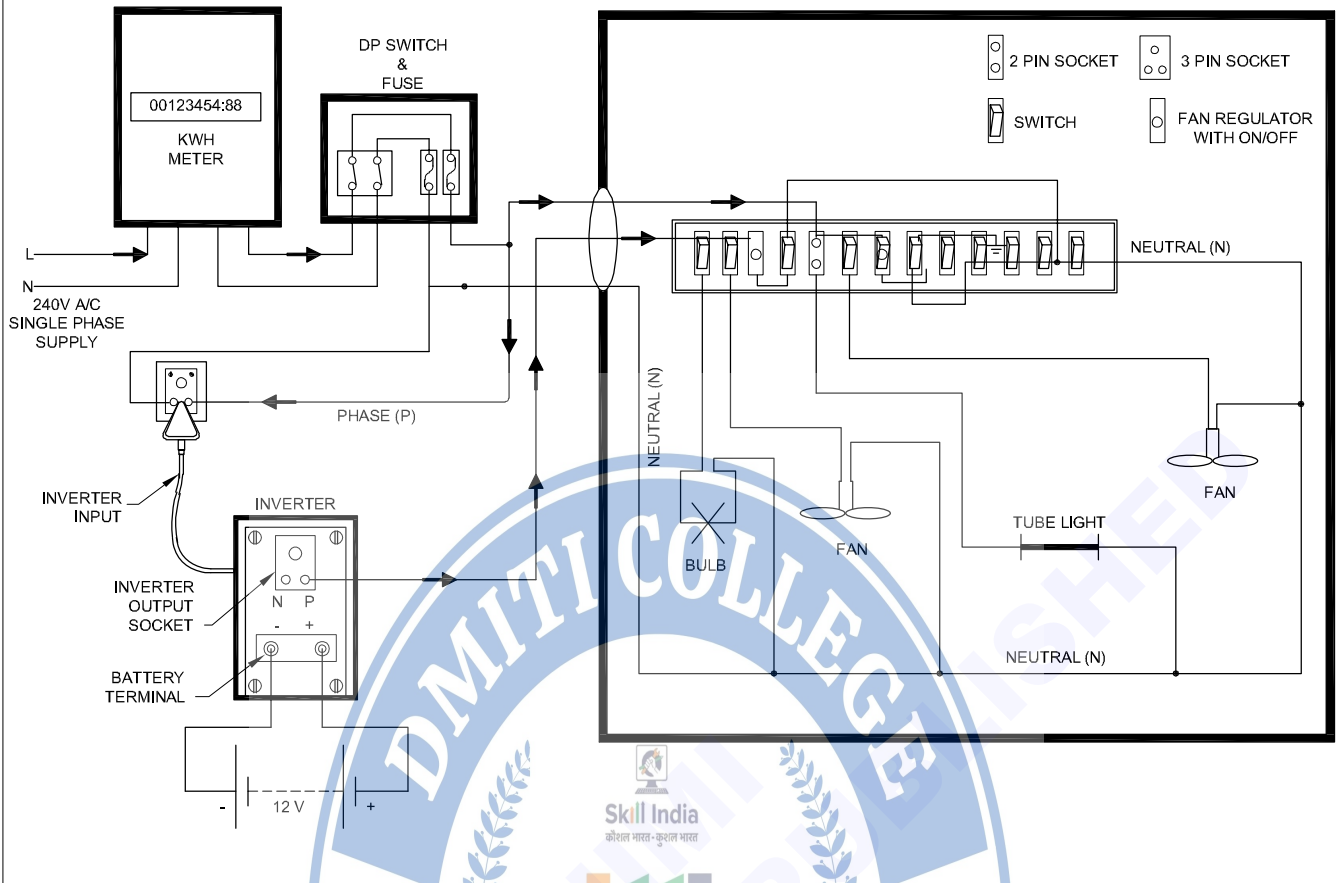

- 11 Connect the ON/OFF switch on the wall panel from the phase output pin of inverter output socket (Fig 1)
- 12 Connect one common Neutral line of both inverter output and mains AC supply.
- 13 Connect only one wire for the phase line from the inverter output socket to the switches.
- 14 Give connection to one bulb, one fan (A) and 2 pin socket only to the inverter output as in Fig 1.
- 15 Connect the other devices in the room i.e the tube light, fan (B) and 3 pin socket directly to the mains AC line.
- 16 Show the connection and get it approved by your instructor.
- 17 Check the operation of inverter during power 'OFF' and then power returns.

If the main supply is 'ON' the load connected to the inverter will get the main AC supply and the other devices which are directly connected to the mains AC supply will also work on the main supply. (Fig 2a)

During power shut down, the devices which are directly connected to the mains AC will stop functioning and the devices connected to the inverter will keep on working on the inverter output . when the mains AC supply returns the inverter will again connect the load to its output. (Fig 2b)

Low wattage load only to be connected on the two pin socket during the power 'OFF' time. Heavy load should not be connected to this socket., such as heater, geyser, motors in HP etc.

Fig 2

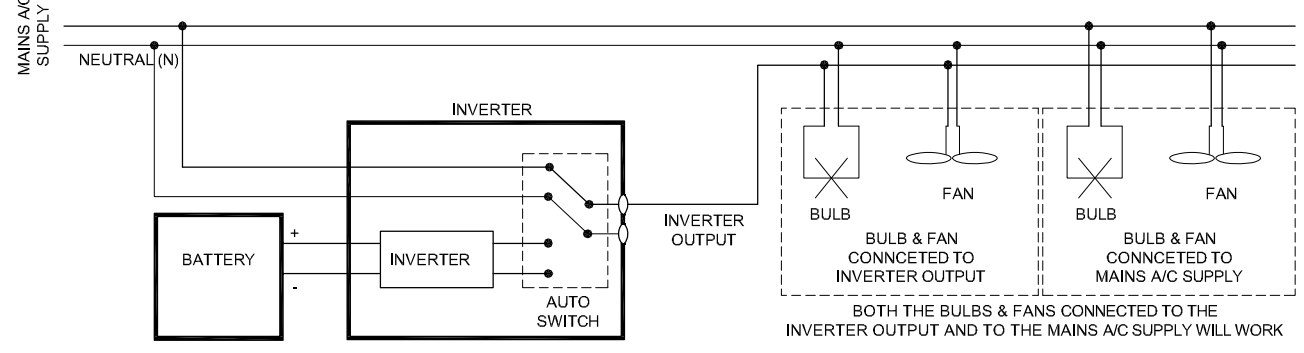

(a)

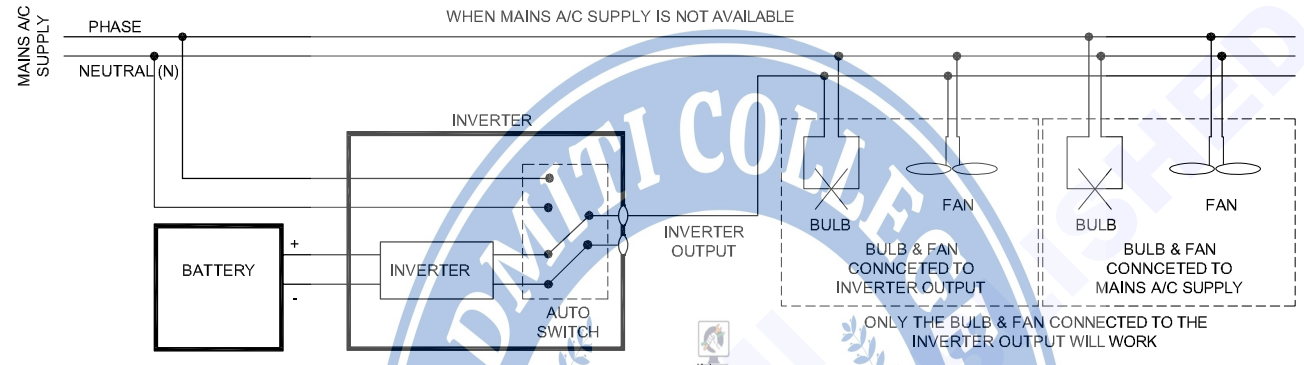

(b)

EL20N210180HZ

